

LIFTING CAPACITY:	LBS.
DIMENSIONS KEY	
A - FLOOR TO FLOOR	
B - CARRIAGE WIDTH	
C - CARRIAGE LENGTH	
D - OVERALL HEIGHT	
E - CARRIAGE THICKNESS	
F - PIT/FLOOR OPENING LENGTH	
G - PIT/FLOOR OPENING WIDTH	
H - PIT DEPTH	
I - LOAD HEIGHT	
J - 1ST FLR TO BTM OF 2ND FLR	
K - 2ND FLOOR TO CEILING	

**FLT
GENERAL ARRANGEMENT
PIT MOUNT**

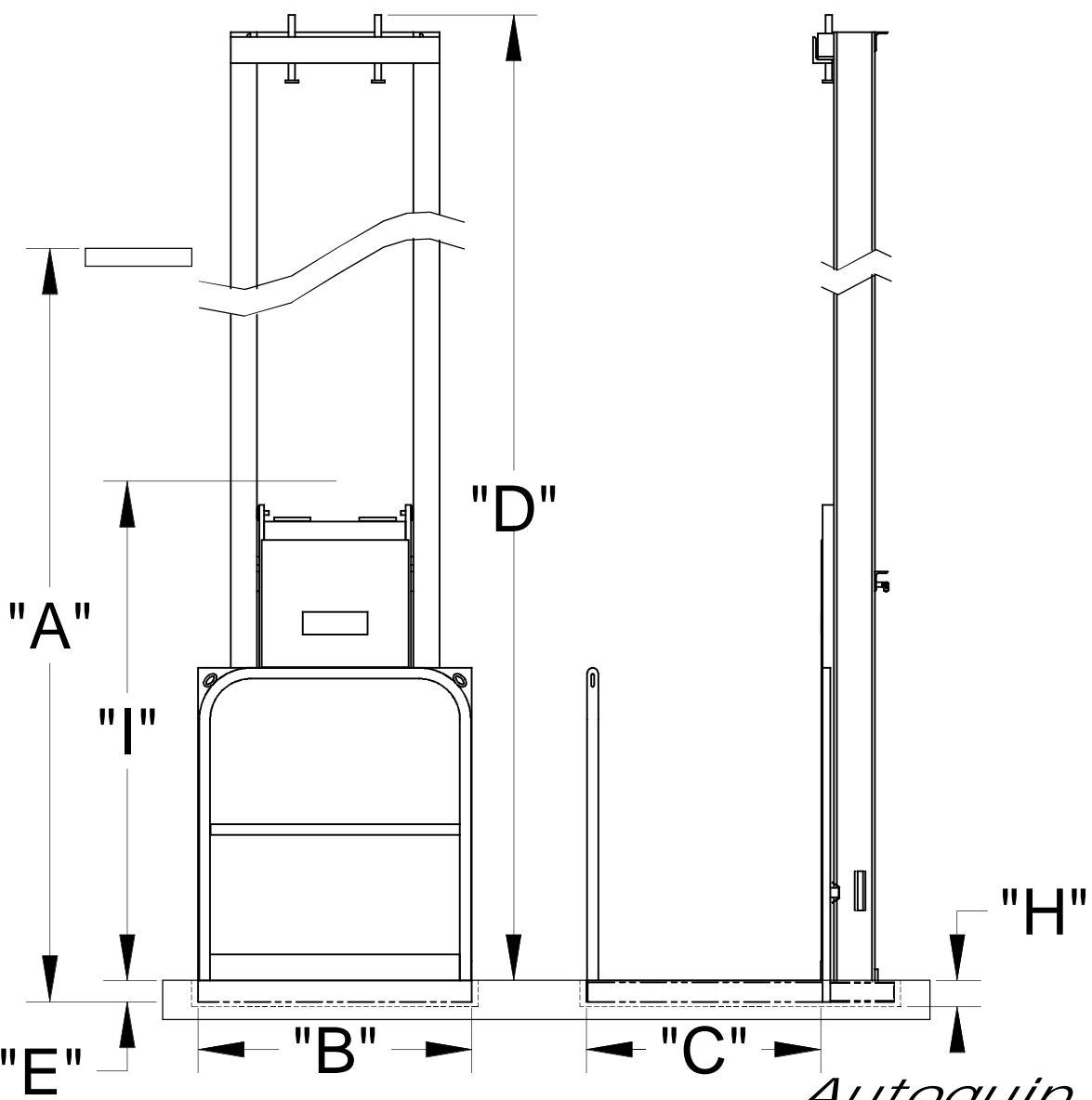
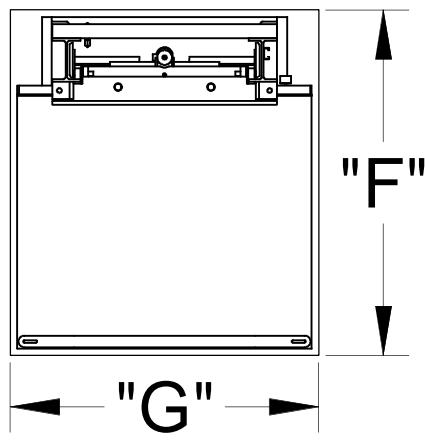

CODE COMPLIANCE
 AUTOQUIP VERTICAL RECIPROCATING CONVEYORS (VRC'S) MEET ALL DESIGN AND SAFETY REQUIREMENTS SET FORTH IN ASME B20.1. AUTOQUIP GUARANTEES ASSISTANCE IN SECURING CODE COMPLIANCE IN ALL 50 STATES. ULTIMATE RESPONSIBILITY FOR GAINING STATE AND LOCAL CODE APPROVAL IS THE RESPONSIBILITY OF THE BUYER OF THE VRC. PLEASE ACQUAINT YOURSELF WITH THE PERMITTING AND/OR LICENSING EXPENSES AND REQUIREMENTS OF THE LOCAL REGULATORY AGENCIES IN THE INSTALLATION AREA.

NOTE:
 THIS DRAWING IS A SALES GUIDELINE ONLY AND IS NOT INTENDED TO BE USED FOR CONSTRUCTION OR BUILDING MODIFICATIONS. ACTUAL DIMENSIONS WILL BE REFLECTED ON THE APPROVAL DRAWING.

NOTE:
 ADDITIONAL GATES AND ENCLOSURES REQUIRED (NOT SHOWN)

NOTE:
 BRACING TO BUILDING STRUCTURE IS REQUIRED. STANDARD BRACING PROVIDED BY AUTOQUIP.

(NOT TO SCALE)
 PROPOSAL DRAWING
 QUOTE NO. _____
 REV. 0 - 11/14/11
 COPYRIGHT RESERVED 2011
 AUTOQUIP CORPORATION
 82601275

NO RIDERS
 THIS LIFT IS NOT AN ELEVATOR AND DOES NOT MEET THE REQUIREMENTS OF ASME A17.1.

Autoquip
 AUTOQUIP CORP.
 1058 W.INDUSTRIAL AVE.
 GUTHRIE, OK 73044-1058
 888-811-9876 WWW.AUTOQUIP.COM

LIFTING CAPACITY:	LBS.
DIMENSIONS KEY	
A - FLOOR TO FLOOR	
B - CARRIAGE WIDTH	
C - CARRIAGE LENGTH	
D - OVERALL HEIGHT	
E - CARRIAGE THICKNESS	
F - PIT/FLOOR OPENING LENGTH	
G - PIT/FLOOR OPENING WIDTH	
H - PIT DEPTH	
I - LOAD HEIGHT	
J - 1ST FLR TO BTM OF 2ND FLR	
K - 2ND FLOOR TO CEILING	

**FLT
GENERAL ARRANGEMENT
PIT MOUNT**

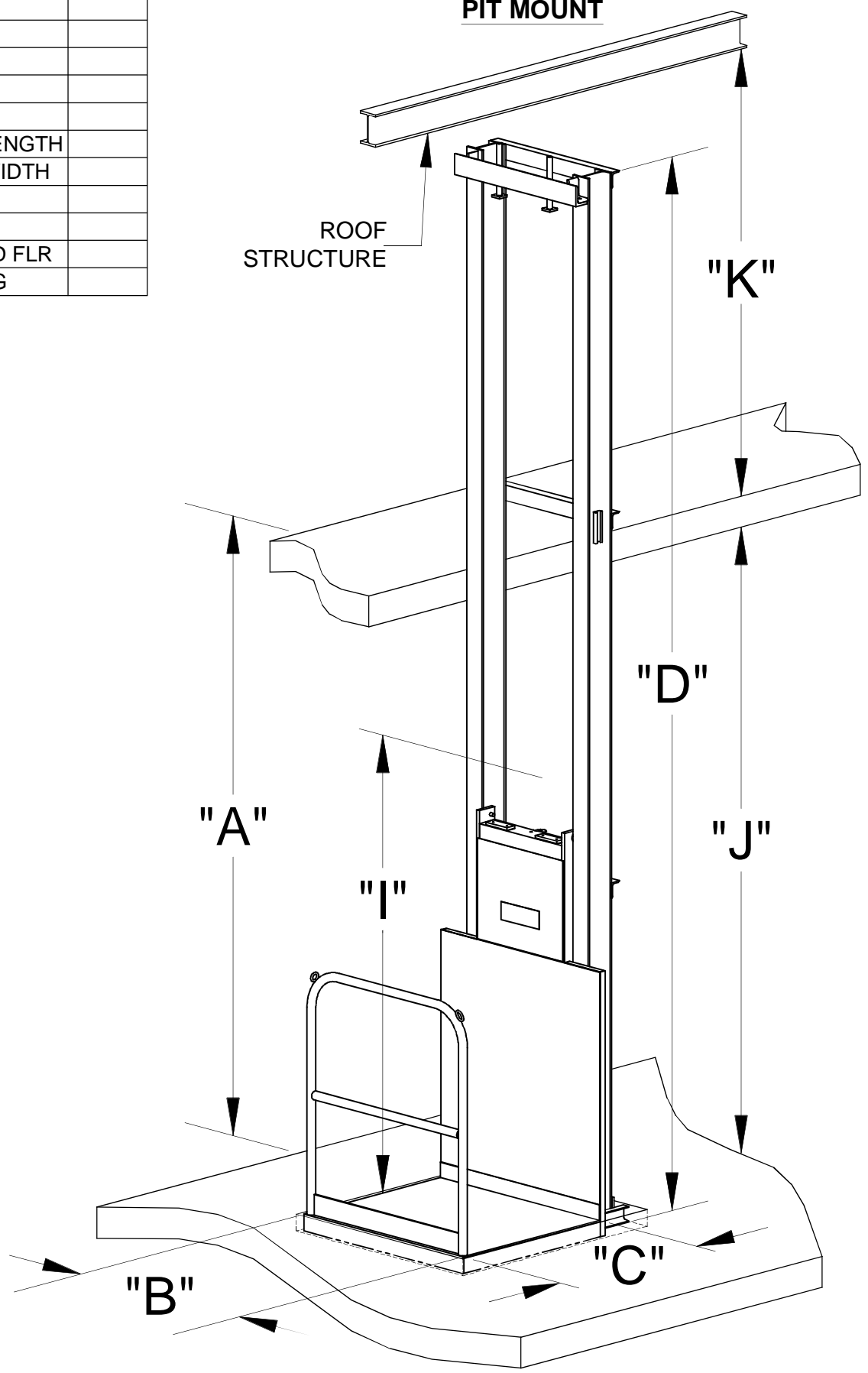

CODE COMPLIANCE
 AUTOQUIP VERTICAL RECIPROCATING CONVEYORS (VRC'S) MEET ALL DESIGN AND SAFETY REQUIREMENTS SET FORTH IN ASME B20.1. AUTOQUIP GUARANTEES ASSISTANCE IN SECURING CODE COMPLIANCE IN ALL 50 STATES. ULTIMATE RESPONSIBILITY FOR GAINING STATE AND LOCAL CODE APPROVAL IS THE RESPONSIBILITY OF THE BUYER OF THE VRC. PLEASE ACQUAINT YOURSELF WITH THE PERMITTING AND/OR LICENSING EXPENSES AND REQUIREMENTS OF THE LOCAL REGULATORY AGENCIES IN THE INSTALLATION AREA.

NOTE:
 THIS DRAWING IS A SALES GUIDELINE ONLY AND IS NOT INTENDED TO BE USED FOR CONSTRUCTION OR BUILDING MODIFICATIONS. ACTUAL DIMENSIONS WILL BE REFLECTED ON THE APPROVAL DRAWING.

NOTE:
 ADDITIONAL GATES AND ENCLOSURES REQUIRED (NOT SHOWN)

NOTE:
 BRACING TO BUILDING STRUCTURE IS REQUIRED. STANDARD BRACING PROVIDED BY AUTOQUIP.

(NOT TO SCALE)
 PROPOSAL DRAWING
 QUOTE NO. _____
 REV. 0 - 11/14/11
 COPYRIGHT RESERVED 2011
 AUTOQUIP CORPORATION
 82601275

NO RIDERS
THIS LIFT IS NOT AN ELEVATOR AND DOES NOT MEET THE REQUIREMENTS OF ASME A17.1.