

NOTES:

1. APPROXIMATE OVERALL DIMENSIONS OF POWER UNIT - 24" x 18" x 12" HIGH.

2. CONTROLS PER QUOTATION.



MOUNTING BRACKETS
 (SUITABLE FOR FLOOR OR WALL MOUNTING)
 4.5 GAL. USEABLE (WALL MOUNT)
 3.3 GAL. USABLE (FLOOR MOUNT)
 (#473-0288-0)

NOTE: ITEM #6 (SUCTION STRAINER AN INTERNAL PART) IS NOT SHOWN.
 (#410-5013-9)

FILLER BREATHER CAP
 (#477-0164-0)



OIL CAPACITY
 5.6 GAL. 9" x 9" x 18"
 POLYEHTYLENE TANK
 (#642-0102-0)



WALL MOUNT
INSTALLATION
SHOWN

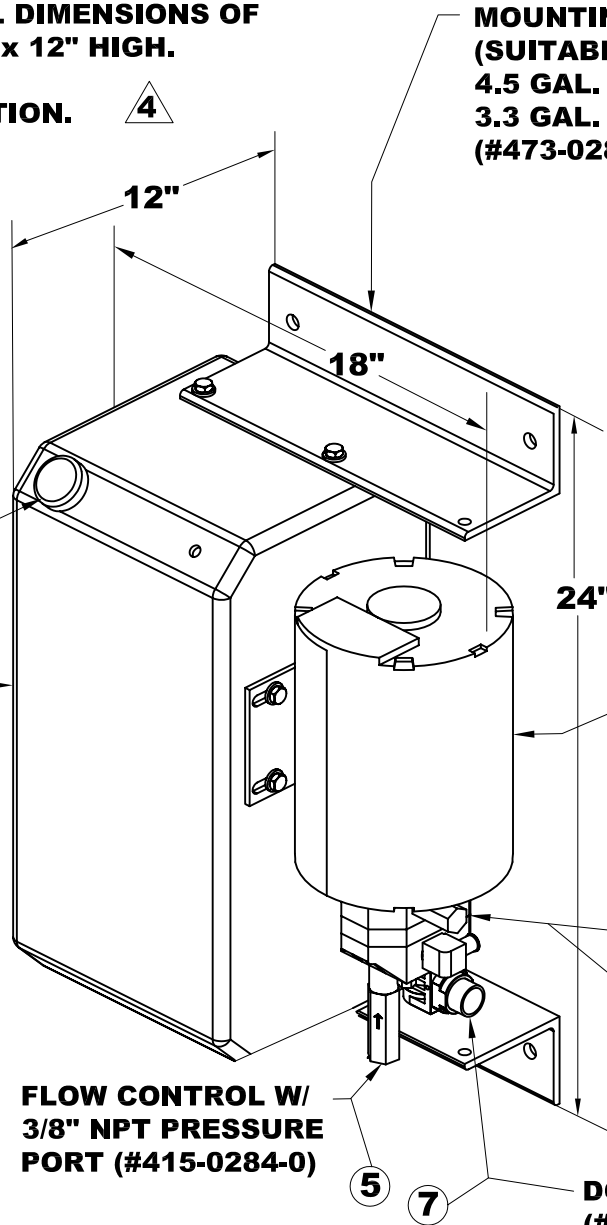

5 HP CONTRACTOR
SUPER TORQUE
TENV MOTOR
 (#306-0061-3)

2.8 GPM PUMP W/ INTERNAL
CHECK, RELIEF, DOWN VALVE
 (#402-0065-0PO)



FLOW CONTROL W/
3/8" NPT PRESSURE
PORT
 (#415-0284-0)



DOWN SOLENOID
 (#327-0129-0 24 VOLT
 #327-0130-0 115 VOLT)

THIS PROPOSAL DRAWING IS GENERIC
BY DESIGN AND IS FOR REFERENCE ONLY.
PLEASE CONTACT AUTOQUIP FOR JOB
SPECIFIC APPROVAL DRAWINGS.

POWER UNIT - CONTRACTOR

(NOT TO SCALE)

PROPOSAL DRAWING

QUOTE NO. _____

826-0084-0 REV 5, 10-24-06



AUTOQUIP CORP.

1058 W.INDUSTRIAL AVE.

GUTHRIE, OK 73044-1058

888-811-9876 WWW.AUTOQUIP.COM

© COPYRIGHT RESERVED
 AUTOQUIP CORPORATION
 2006