

NOTES:

1. ALL AXLES, ROLLERS AND PIVOT POINTS ARE EQUIPPED WITH LIFE-TIME LUBRICATED BEARINGS.
2. LIFT TO BE PAINTED AQ STANDARD ENAMEL.
3. MEETS OR EXCEED ANSI MH29.1 STANDARD FOR INDUSTRIAL SCISSORS LIFTS.

THIS PROPOSAL DRAWING IS GENERIC BY DESIGN AND IS FOR REFERENCE ONLY. PLEASE CONTACT AUTOQUIP FOR JOB SPECIFIC APPROVAL DRAWINGS.

MODEL NO: _____

MAX CAPACITY: _____

LOWERED HEIGHT: _____

TRAVEL: _____

RAISED HEIGHT: _____

POWER UNIT, CONTROLS, AND ACCESSORIES PER QUOTATION.

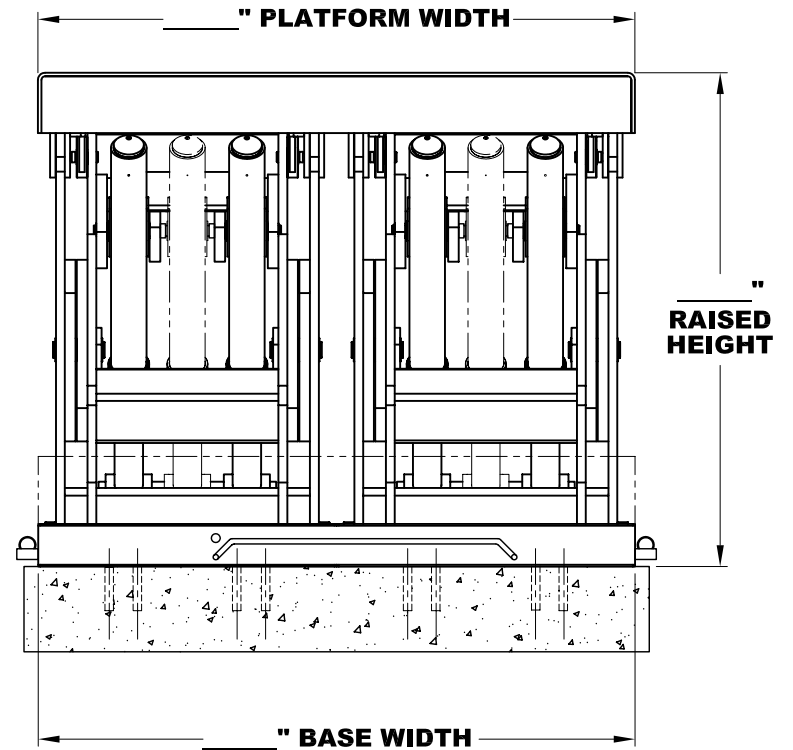
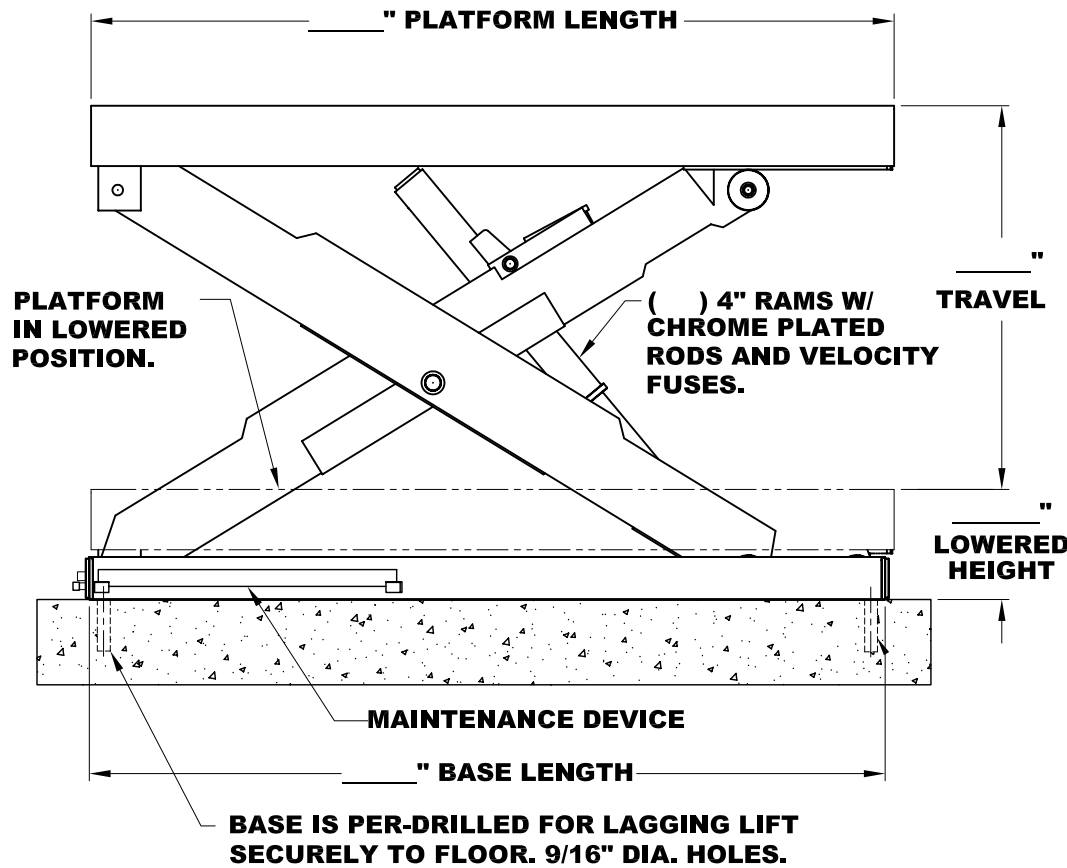

(NOT TO SCALE)
 PROPOSAL DRAWING
 QUOTE NO. _____
 82601240

SUPERTITAN - DOUBLE WIDE



AUTOQUIP CORP.
 1058 W.INDUSTRIAL AVE.
 GUTHRIE, OK 73044-1058
 888-811-9876 WWW.AUTOQUIP.COM